

DATA SHEET

RV 2.1944

RADIAL BLOWERS

air-cooled

with external VARIAIR frequency inverter

MAKE IT BECKER.

LARGE VOLUME FLOW
with a compact design

EXACT ADAPTATION TO DEMAND

due to large control range up to a maximum
of 400 Hz of the external frequency inverter

**ENERGY-EFFICIENT
OPERATION**

because of high efficiency

**SIMPLE AND FLEXIBLE
SYSTEM INTEGRATION**

even without a pedestal

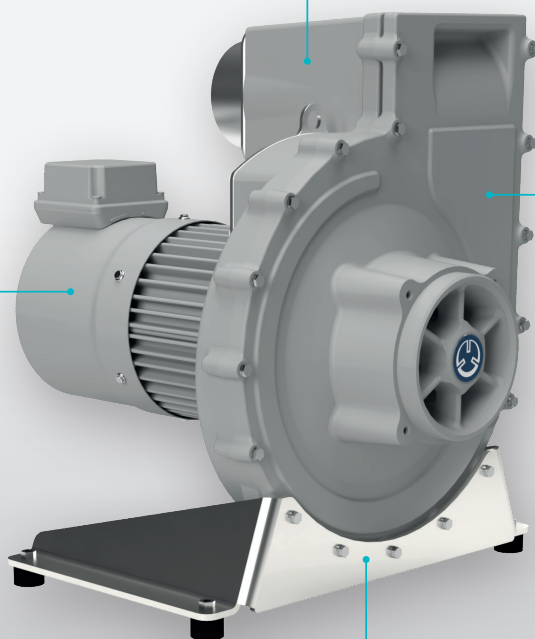

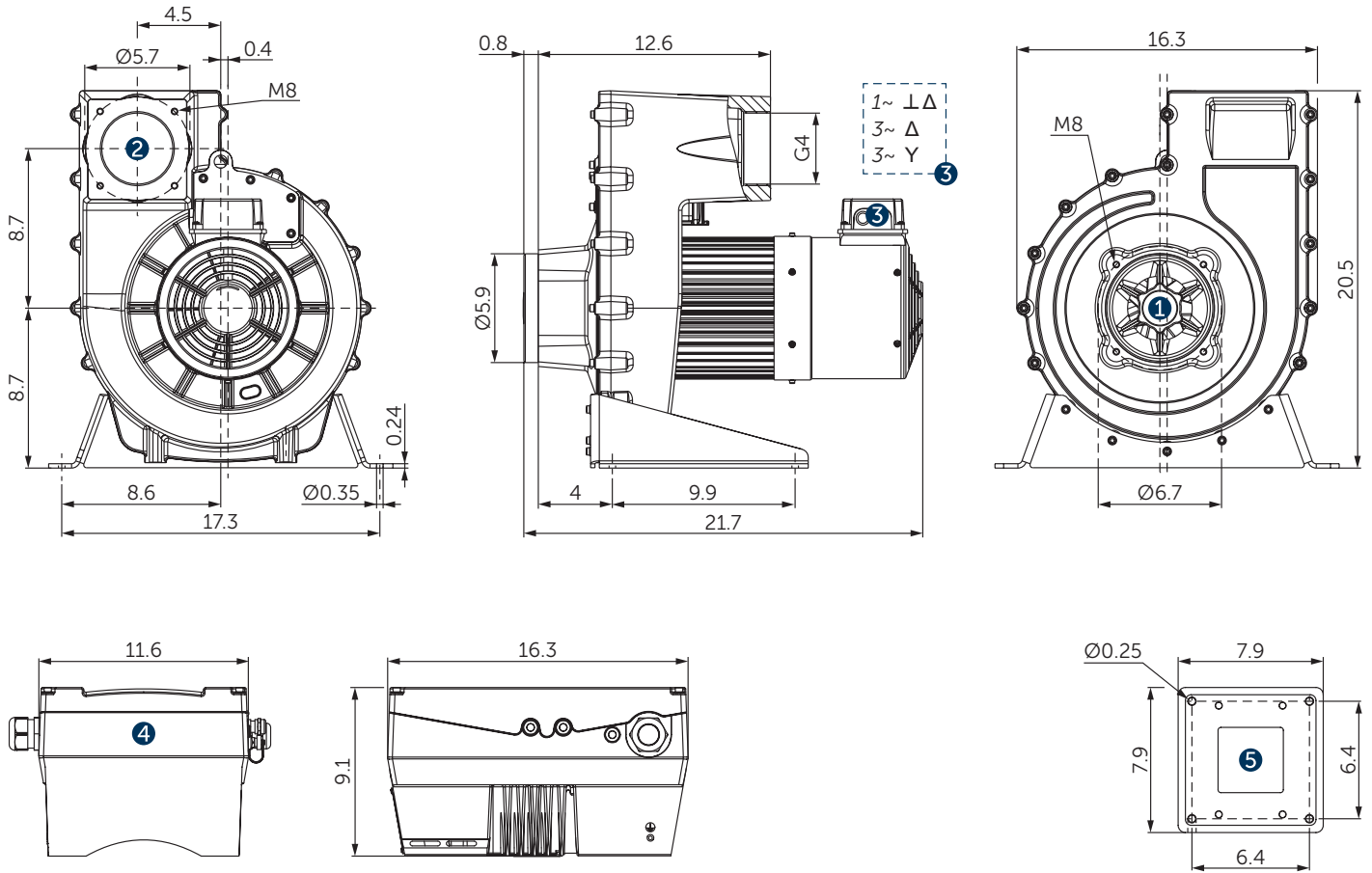

- 1 Vacuum connection
- 2 Pressure connection
- 3 Connection/pin assignment motor fan
- 4 Frequency inverter
- 5 Wall mount for frequency inverter
- Dimensions in inch

Blast air rate	Pressure		Frequency	Emission sound pressure level ¹⁾	Weight w/o inverter	
	CFM	in. H ₂ O				
max.	max.	max.		@ 72.4 in. H ₂ O (350 Hz)		Frequency inverter
923	164.9	5.9	≤400	75	132.3	400–480 V ±10% • 50/60 Hz 46.3 lbs

¹⁾ DIN EN ISO 3744 (KpA = 3 dB(A)) interval of 39.4 inch, at medium load, both connection sides piped
 ▪ Frequency inverter incl. wall mount; cable length between frequency inverter and radial vacuum pump max. 4.0 m [157.6 inch]

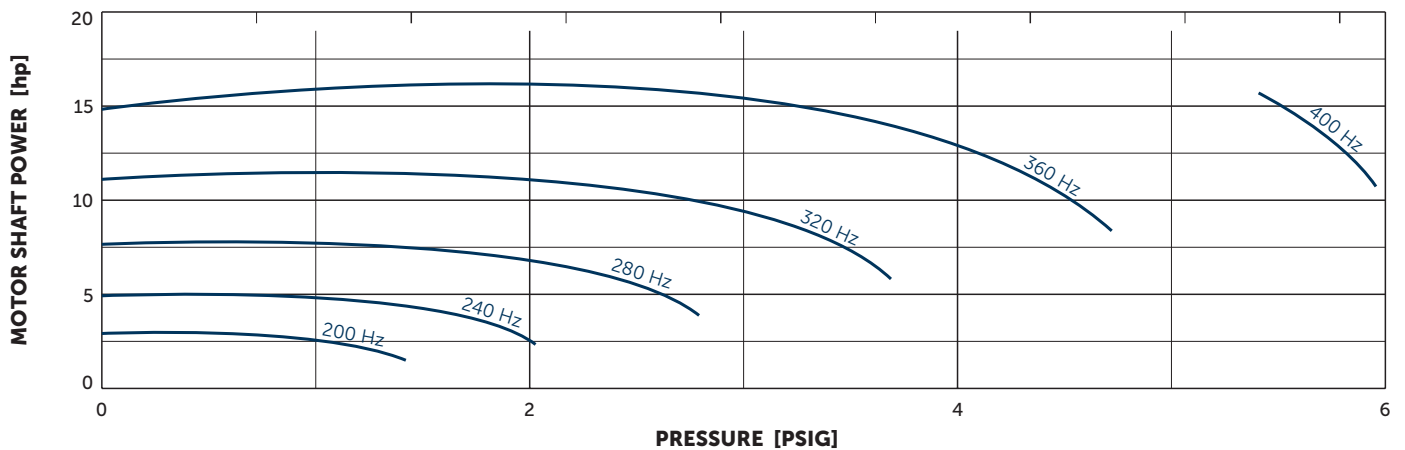
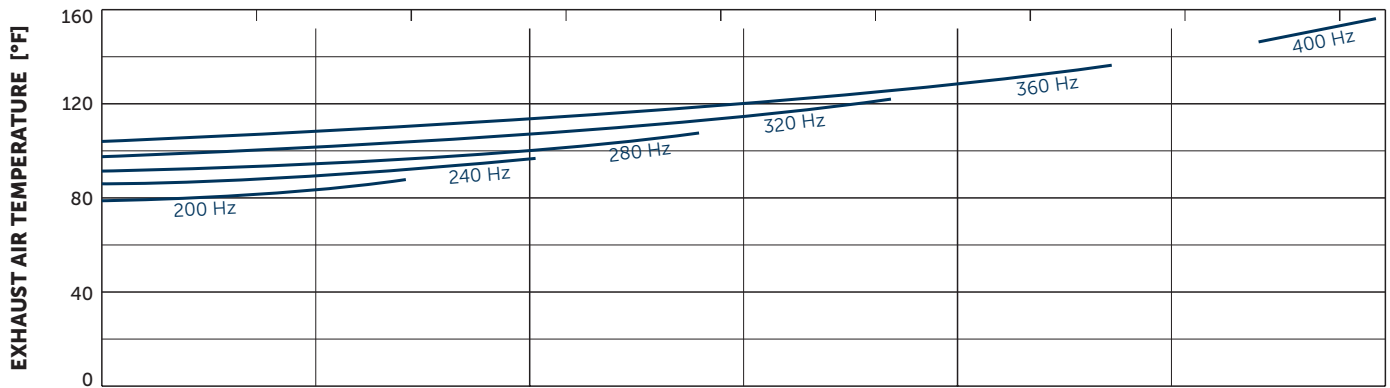
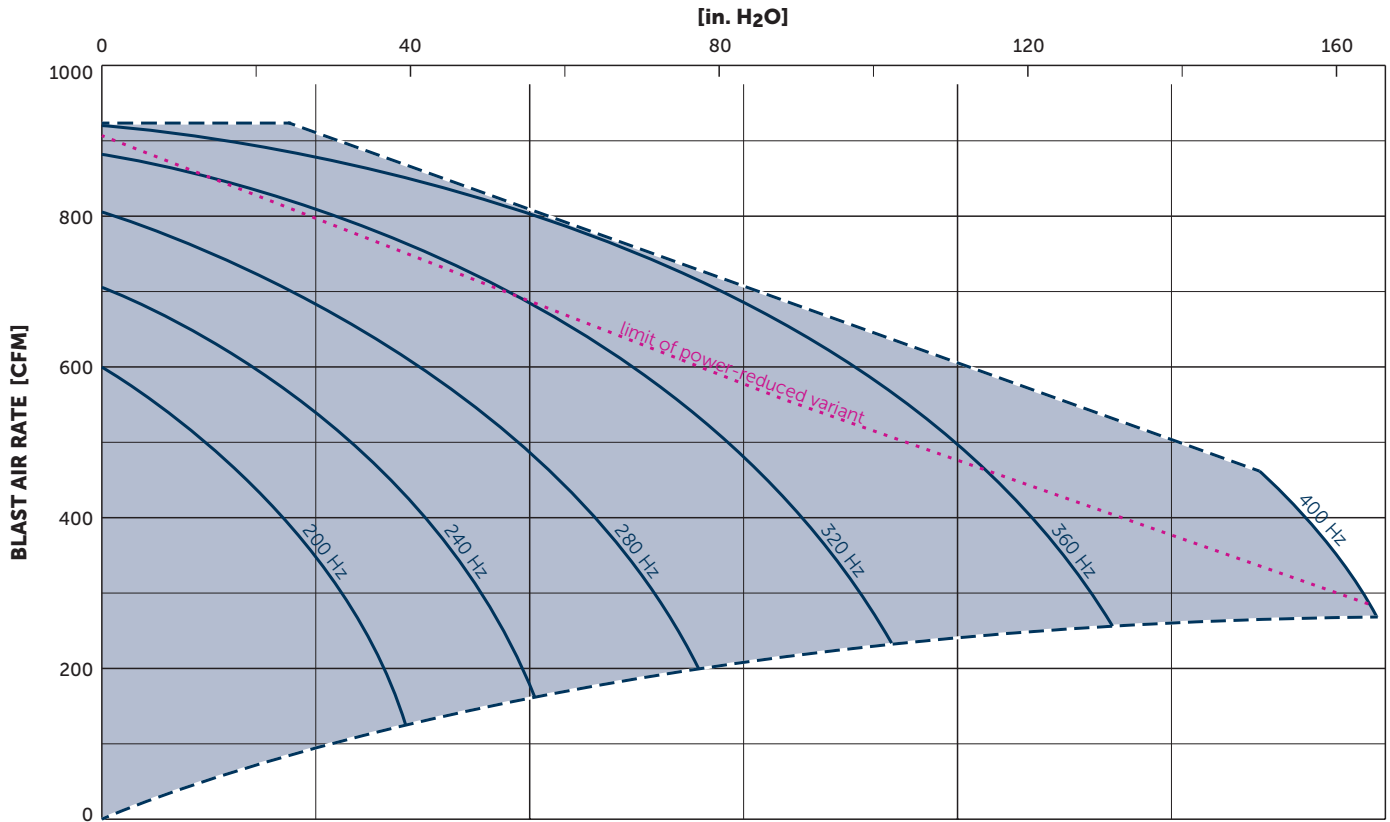

Reference data (atmosphere): 0 in. HgV, 68°F
 Tolerance: ±5%

+ VARIANTS AND ACCESSORIES

- VARIAIR RV 2.1944 power-reduced, see characteristic diagram
- VARIAIR RV 2.1944 including **suction filter RV 2.19**¹⁾ with transparent service cover, large filter surface and variable suction connection position; optionally with integrated non-return flap

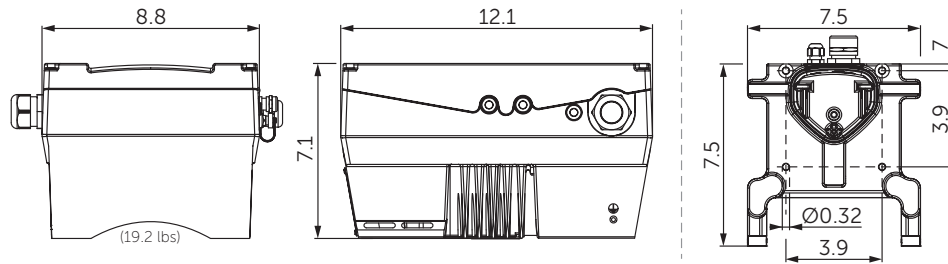

Frequency inverter for the power-reduced RV 2.1944 | Wall mount



Suction filter RV 2.19

¹⁾ See separate data sheet

MAKE IT BECKER.

HOMEPAGE
RV/VATP SERIES



ONLINE SHOP
RV 2.1944



www.beckerpumps.com
www.becker-international.com

