

DATA SHEET

# VARIAIR KVT 3.140/0-400

## ROTARY VANE VACUUM PUMPS

oil-free, air-cooled  
frequency inverter

**MAKE IT BECKER.**



figure VARIAIR KVT 3.80/0-400

**VARIAIR**  
UNIT

 **BECKER**

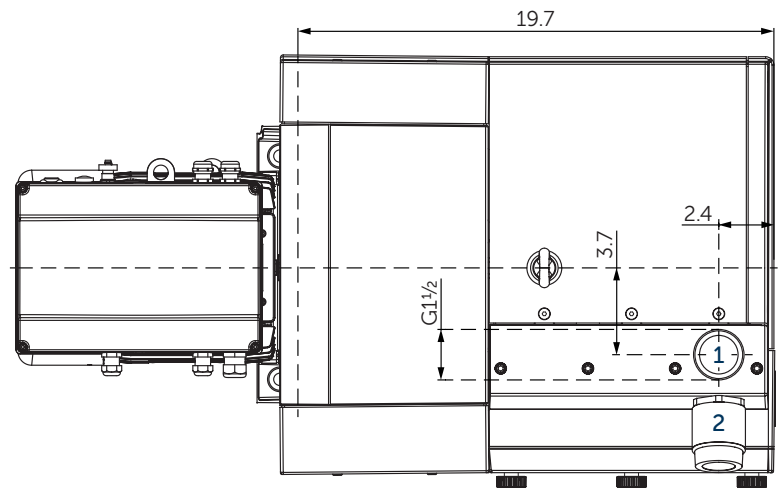
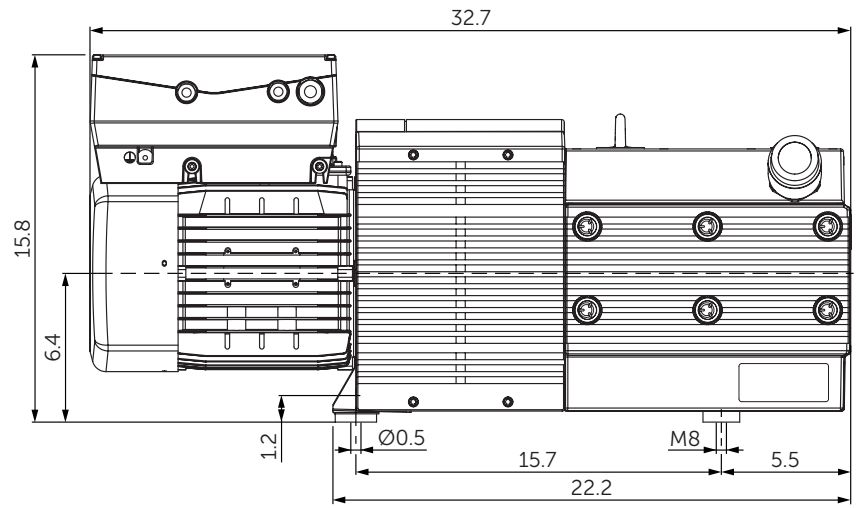
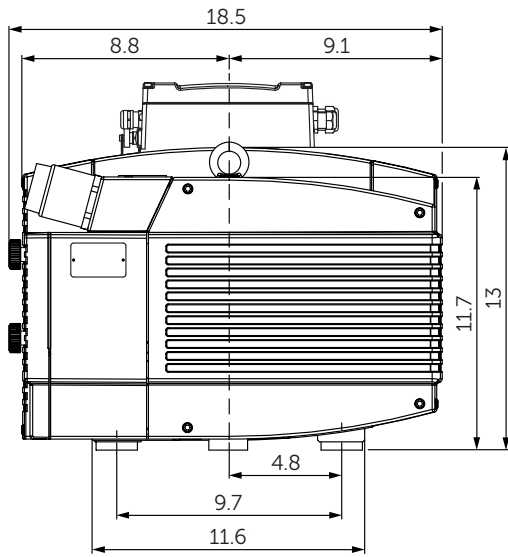

- 1 Vacuum connection (G1½)
- 2 Vacuum regulating valve
  - Including integrated suction air filter and blow of valve
  - The motor illustration may vary.
  - Dimensions in inch

Suction air rate	Vacuum	Frequency	Emission sound pressure level <sup>1)</sup>	Weight	Frequency inverter VAU4/4	A max.
CFM max.	in. HgV max.	Hz	dB(A) @ 19.9 in. HgV (40 Hz)	lbs	5.4 hp 400-480 V ±10% 50/60 Hz	16
85	26.6	30-60	77.9	254.7		

<sup>1)</sup> According to DIN EN ISO 3744 (KpA = 3 dB(A)), 39.4 inch distance, at medium load, both connection sides piped

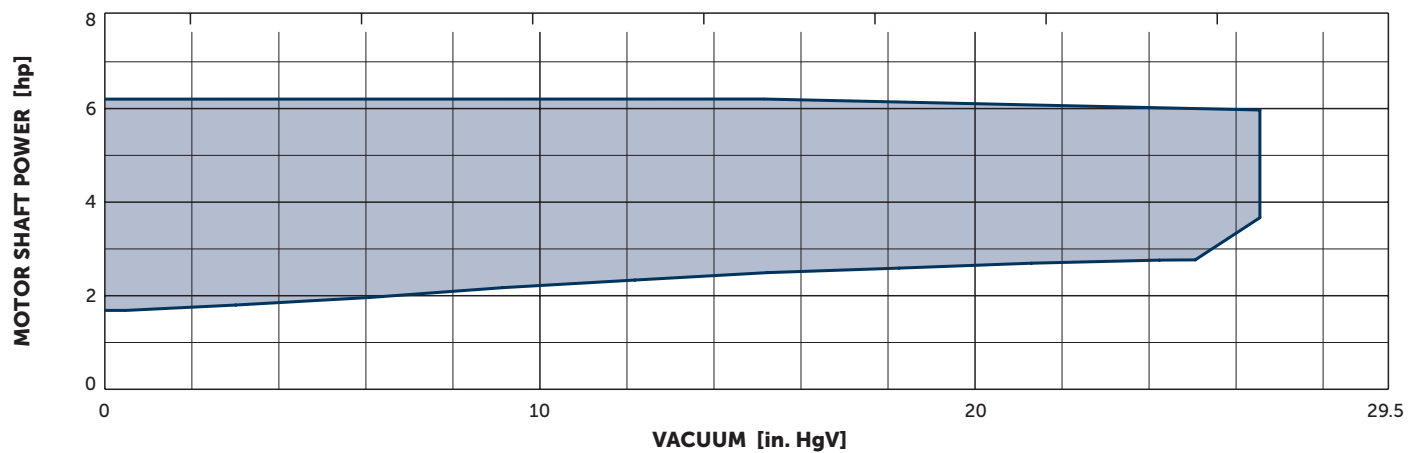
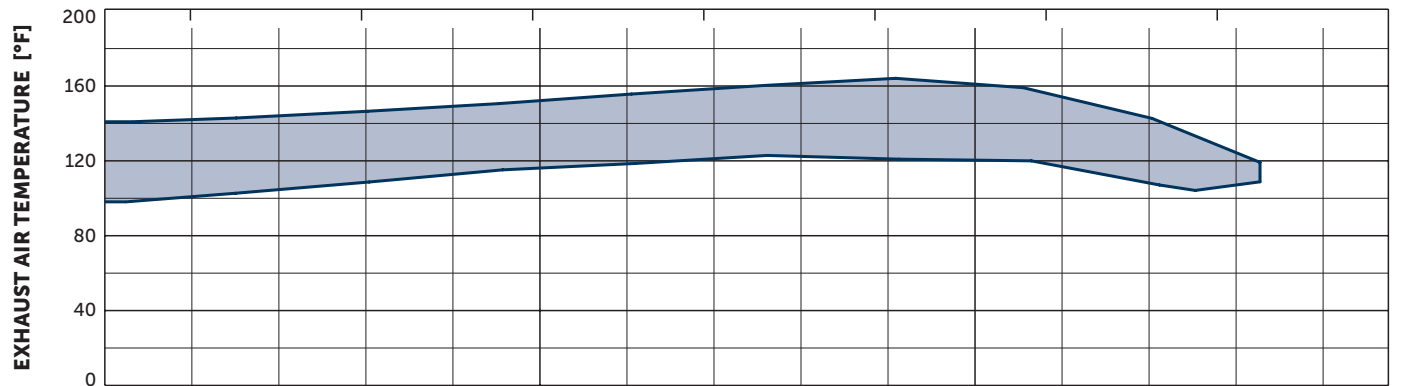
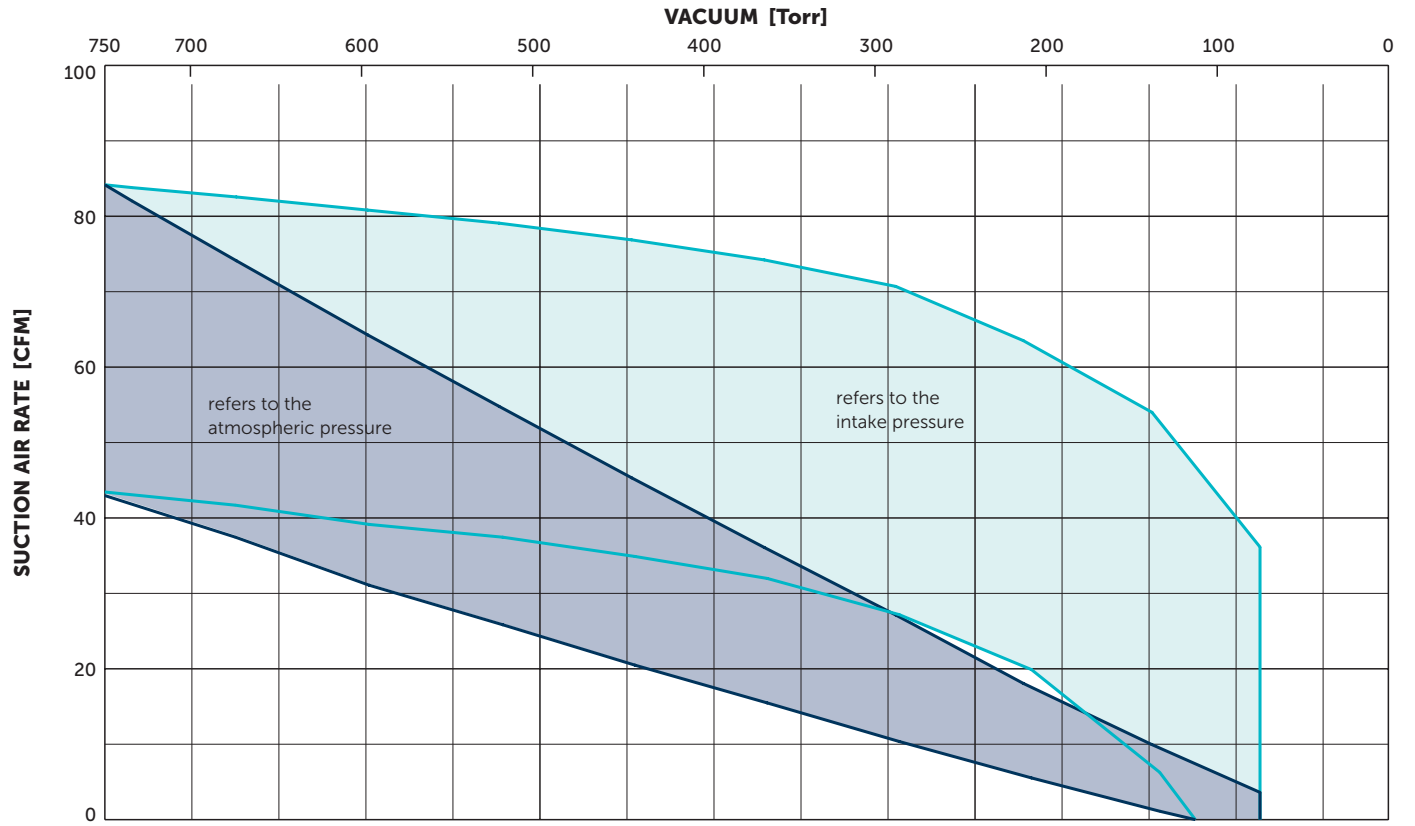

Reference data (atmosphere): 0 in. HgV, 68°F; Tolerance: ±5%



**MAKE IT BECKER.**