

BETRIEBSANLEITUNG
OPERATING INSTRUCTIONS
INSTRUCCIONES DE SERVICE
ISTRUZIONI D'USO
HANDLEIDING
INSTRUCCIONES PARA EL MANEJO
MANUAL DE INSTRUÇÕES
NAUDOJIMOSI INSTRUKCIJA
KASUTUSJUHEND
LIETOŠANAS INSTRUKCIJA
DRIFTSINSTRUKS
DRIFTSINSTRUKTIONER
DRIFTSVEJLEDNING
INSTRUKCJA OBSŁUGI

KEZELÉSI ÚTMUTATÓ
NÁVOD K OBSLUZE
NAVODILO ZA UPORABO
NÁVOD NA OBSLUHU
UPUTE ZA RAD
MANUAL DE OPERATII
TREORACHA OIBRIÚCHÁIN
ΟΔΗΓΙΕΣ ΧΡΗΣΗΣ
EL KITABI
ИНСТРУКЦИИ ЗА ЕКСПЛОАТАЦИЯ
ИНСТРУКЦИЯ ПО ЕКСПЛОАТАЦИИ
取扱説明書
사용설명서
使用说明书

BCV 100

MAKE IT BECKER.

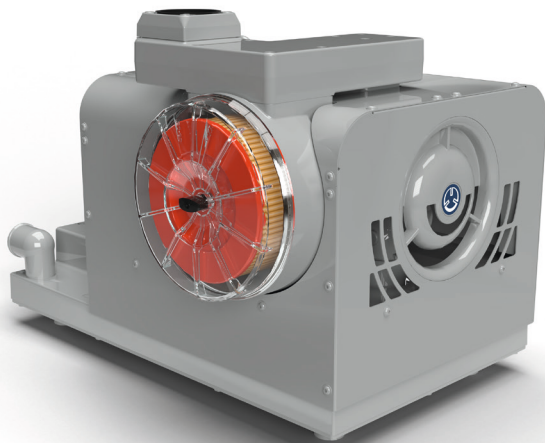

Type 1
with integrated filter

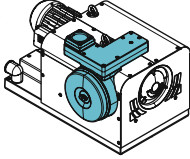

Type 2
without filter
for external filtration

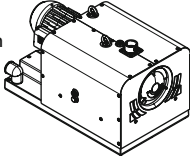



1





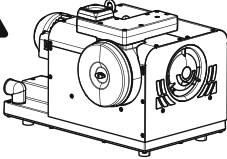

www.becker-international.com

2

AIR

3

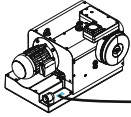

BECKER	year
No.	
CE type	Hz
frequency	min ⁻¹
speed	min ⁻¹
power required	kW
inlet capacity	m ³ /h
vacuum	mbar
Made in Germany	

DIN EN ISO 11203
Accuracy Class 2
K_{pA} = 3 dB(A)
l ← 1m

L_{pA} = 69 dB(A) - 50Hz
L_{pA} = 72 dB(A) - 60Hz

m³/h
mbar

4



INLET AIR

> 0°C/32°F
< 40°C/104°F

> 0°C/32°F
< 40°C/104°F

Avoid condensation
max. 90%



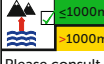

Please consult
BECKER

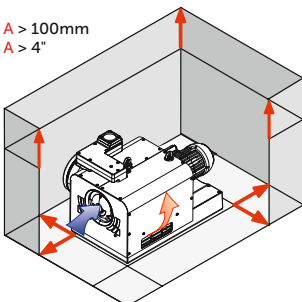

A > 100mm
A > 4"



5

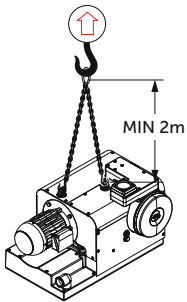





MIN 2m

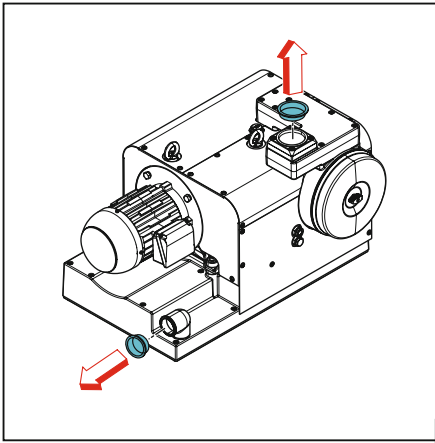

170 kg
375 lbs

6



7

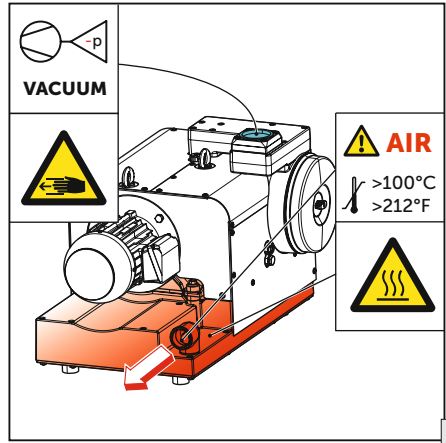

8

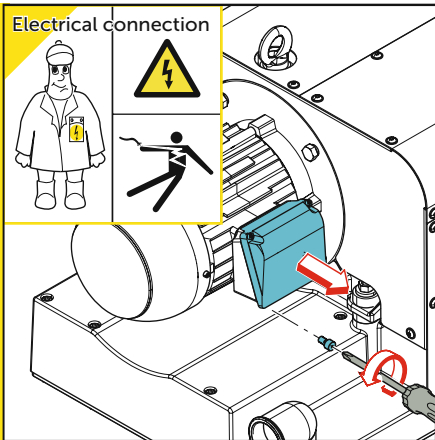

9

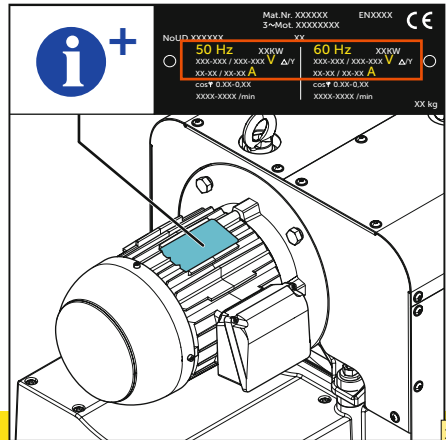

10

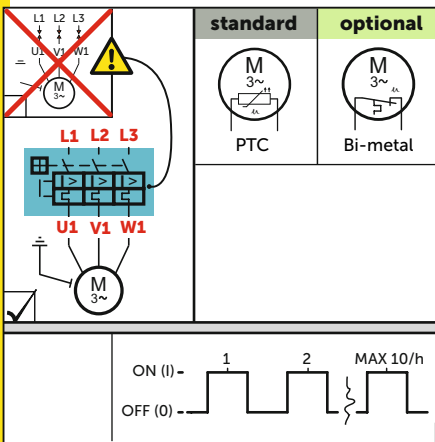

11

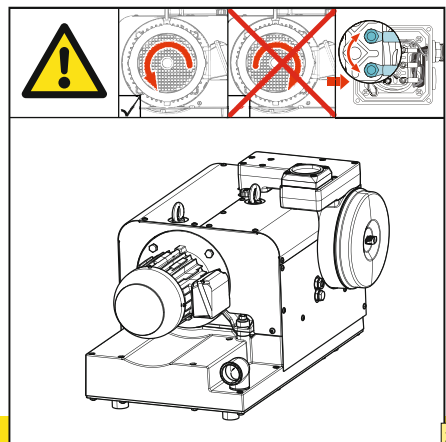

12

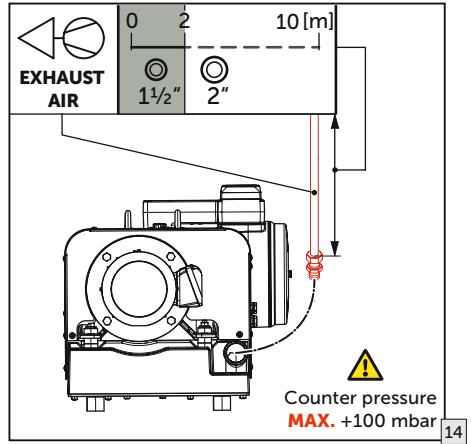
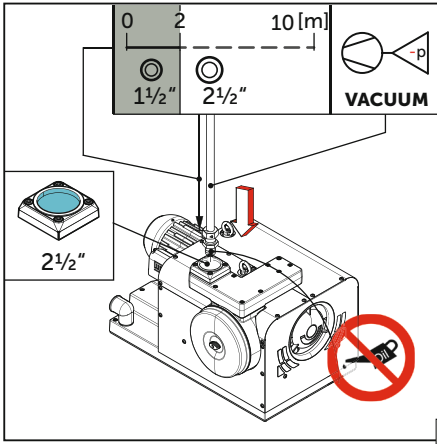

Maintenance

BECKER

15

OFF ON

$n=0 \text{ min}^{-1}$

1 Min

16

MAX MIN

check regularly **4x/year**

< MIN

Becker Lube G 150

OFF

17

20.000 operating hours every **3 years**

Ambient temp. **!**





40°C 20°C

5.000h 20.000h



Operating hours

OIL

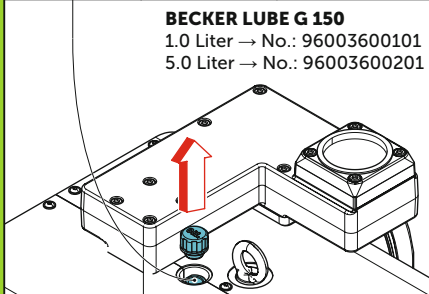
18

 0.75 Liter	 MAX	 
<p>BECKER LUBE G 150 1.0 Liter → No.: 96003600101 5.0 Liter → No.: 96003600201</p> 		

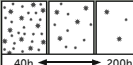
19

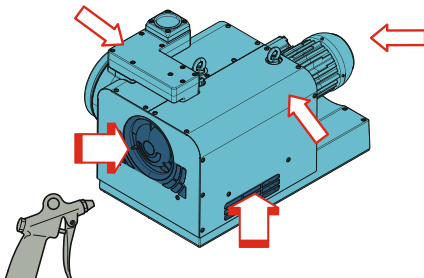
 40 - 200 h	 AMBIENT AIR ?	 EN149 - FFP3 42 CFR 84 - N100
		

20

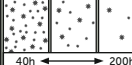
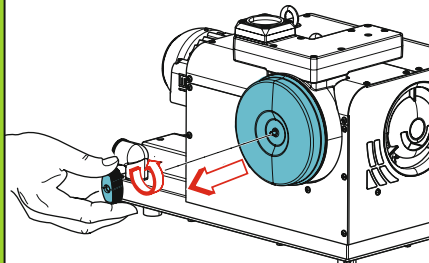
 40 - 200 h	 INTAKE AIR ?	MIN 1x/a
		

21

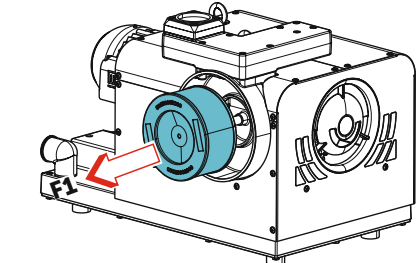
 F1	1x No.: 90950065200 (PAPER) 1x No.: 90950165200 (POLYESTER)
	

22



WWW.BECKER-INTERNATIONAL-SHOP.COM

Gebr. Becker GmbH
 Hoelker Feld 29-31
 42279 WUPPERTAL
 GERMANY
info@becker-international.com
www.becker-international.com





MAKE IT BECKER.

28100065110 | 2020-01-10 | Alle Rechte vorbehalten