

**DT Series:** The DT series compressor models work on the principle of a positive-displacement pump that consists of vanes mounted in a rotor, rotating inside of a cylinder. The carbon graphite composite vanes slide into and out of the rotor freely sealing on all edges creating chambers totally oil free.

**Product Description:** The Becker DT 4.4, 4.8, 4.10, 4.16, 4.25, 4.40 series compressors are 100% oil-less rotary vane compressor pumps designed to operate on a continuous basis at any point from atmospheric pressure to a pressure level of 14.5 psig. The DT series compressors are direct drive units and are supplied with a TEFC flange mounted electric motor. Each pump is equipped with an integral pressure relief valve, a 10 micron inlet filter, and vibration isolators as standard equipment. **Prior to handling the compressor pump, these operating, installation and safety instructions shall be read and understood.**

Check boxes next to explanation if you have understood the information.

Call factory for any concerns.



The DT series are dry rotary vane non-polluting compressors intended for the compression of air and other dry inert gases. Maximum Allowed Temperature of the inlet air/inert gas - **113 deg F. (45 deg C)** Ambient temperature: **41-113 deg F** Ambient pressure:



**Warning. Danger. Caution.** Note that ignoring notices may lead to accidents; minor, serious or fatal injuries to personnel; or may cause damage to the pump. If anything remains to be clarified, please contact your Becker Pumps representative.

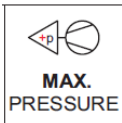

The compressor pump is set up for continuous operation to a pressure of 14.5 psig, intended for use in processes involving air and other dry, non-aggressive, non-toxic and non-explosive gases. The proper function of the compressor requires ambient pressure to be present at the inlet throughout any operating point. Conveying lower/higher density media leads to possible excessive thermal/mechanical load on the compressor pump. Please consult with Becker Pumps when conveying these other vapors/media.



Inlet ambient pressure air shall be free from vapors that would condensate under the temperature and pressure conditions inside the compressor. Liquids may not be conveyed.



The compressor pump should be placed in a non-potentially flammable/explosive/non-toxic environment. Therefore:



Flammable Substances may not be conveyed.



Explosive substances may not be conveyed.



The pump is a dry rotary vane pump that compresses air and works without oil. **(No oil)** Avoid absorption of oil fumes.



The compressor will become **very hot** during operation. This is normal. Care should be taken to let the unit cool down before maintenance. **(High temps: 175 + degrees F (79 + degrees C))**

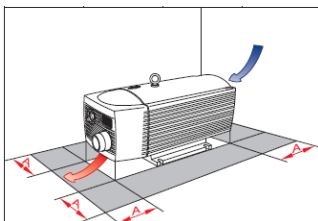

Cooling takes place by radiating heat from the surface of the pump; air flow from the fan wheel across the drive motor and from the air flow of the fan wheel on the shaft of the compressor pump.

**A > 100mm**

**A > 4"**



Greater than 4" (100 mm) around the pump is the distance from any object for radiant heat dissipation. Allow even more area to provide access for maintenance of the pump.



The ambient inlet air will also supply cooling to the pump. This air nozzle inlet air and the surrounding ambient air should be within temperatures between 41 deg F – 113 deg F.

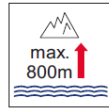

Characteristic data from the spec sheet is valid up to 2625 ft (800 m). Consult with Becker for corrected specifications at altitude. The relief valve on the pump will need to be adjusted.



Protect the pump from humidity in storage/assembly. If placing the pump outside, protect from the outside elements by a protective roof and from rodent/vermin by blocking inlets with wire mesh fencing. Working environment and process application should convey air with a relative humidity between 30-90%.

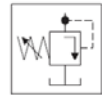

The compressor pump is equipped with a safety pressure relief valve. The relief valve is set for the max pressure level of the pump at sea level. The relief valve prevents back pressure to the pump by opening, allowing air to escape when max pressure of the pump has been attained. The inlet port and the valve itself must be free from obstruction. (In high altitude applications, the relief valve will be reset for the correct relief at the adapted pressure level at altitude.)

## SET-UP/ ASSEMBLY: Review and identify the position of the (see next page):

- Pressure Connection** (install piping of the pressure/blast line from the port to the process without restriction)
- Air nozzle port** (leave open to atmosphere without restriction).
- Review and identify** dimensions of the pump, location of inlet filters (to avoid suction of any foreign media), the non-return valve (to avoid reverse rotation after switching off the compressor pump), and locate the arrows that indicate correct rotation of motor/fan after electrical hook-up.
- Do **not reverse rotation** of the pump, this will spin the vanes backwards incorrectly and possibly break or chip vanes).

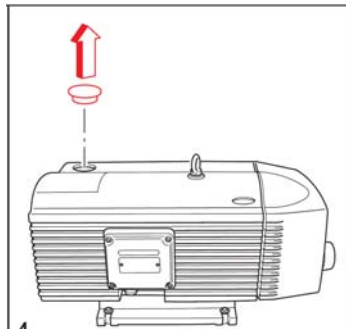

**Remove all packing materials:** cardboard/plastic covers/adhesive tape/foam from all ports and from the outside of the pump.

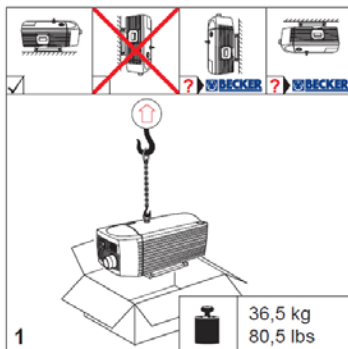

Make sure the eyebolt is fully screwed in. The position of the eyebolts fit to the center of gravity of a pump including the integrated drive motor. The pump has one suitable position which is sitting on its' base plate.



□ The pump is intended for industrial use. It shall be handled only by qualified personnel. Only qualified personnel shall transport, store, install, commission, maintain, troubleshoot, and overhaul the pump. The installation of the pump should be observed both by the manufacturer of the machinery into which the pump will be incorporated and by the operator. Marked operations may only be executed by qualified electricians.

□ **Follow all safety notes/warnings.**

Always wear eye protection.

□ During operation, the surface of the pump may reach high temperatures of more than 160 deg F. Wear protective gloves, stay clear of the pump. Risk of Burns!

□ The pump emits noise of high intensity in a narrow band. Risk of damage to hearing. Persons in the vicinity of a pump over extended periods shall wear ear protection.

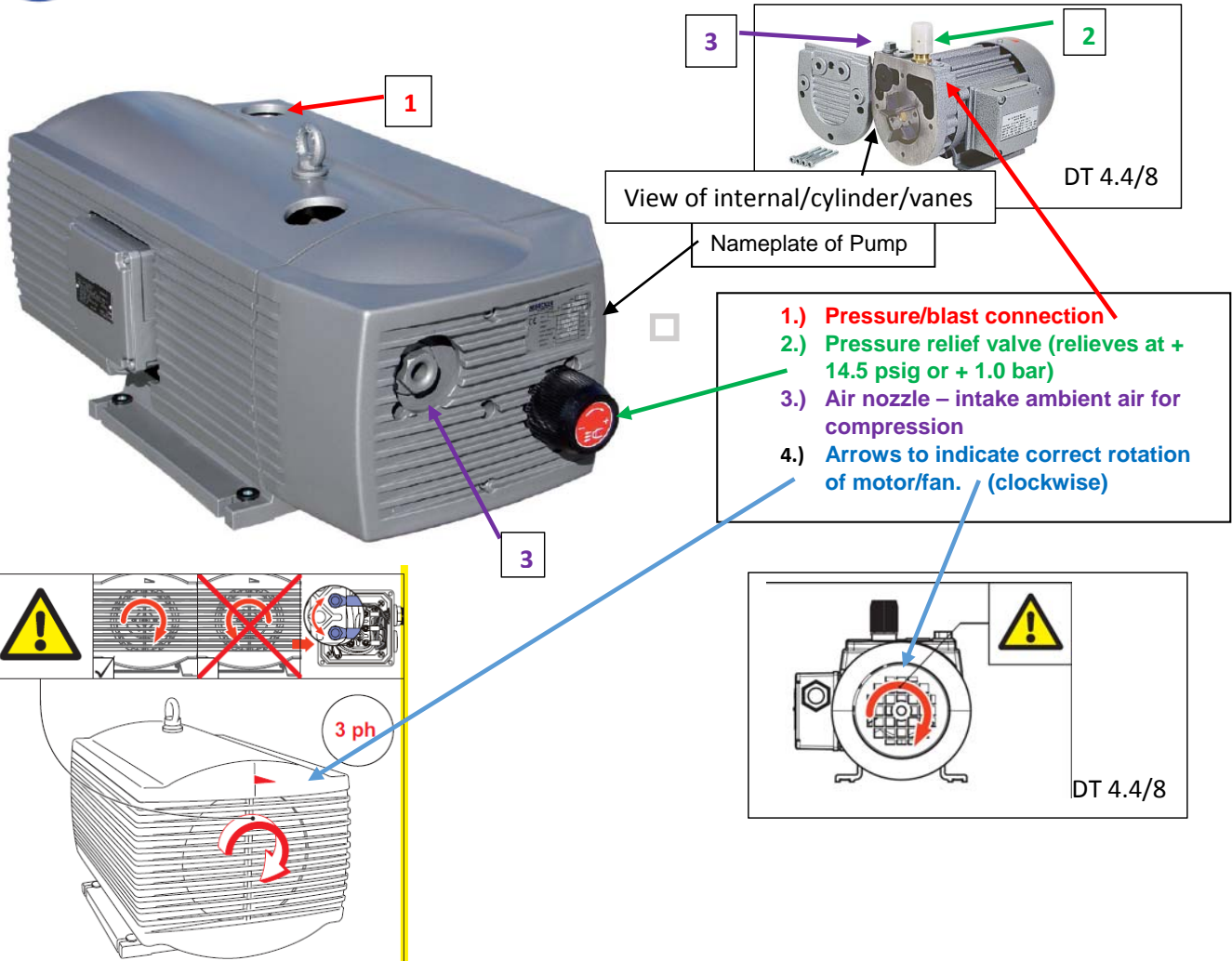

□ When servicing the pump, the pump must be turned off. The motor must be disconnected from the main electrical source by a qualified electrician so that it cannot be started up again accidentally. Lockout the motor.

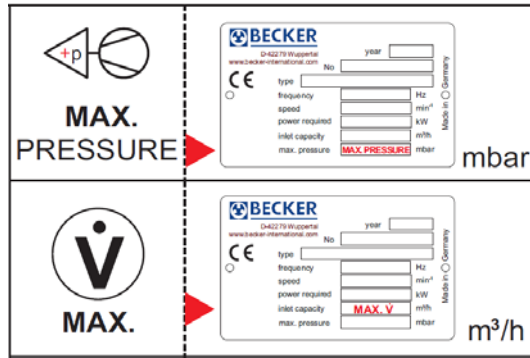

On every pump there will be the **pump nameplate**. It will state: the year the pump was manufactured, the serial number of the pump, the type of pump, frequency, rpm, kW (motor HP), volumetric flow inlet capacity, and the max pressure. The data sheet will also provide this information.

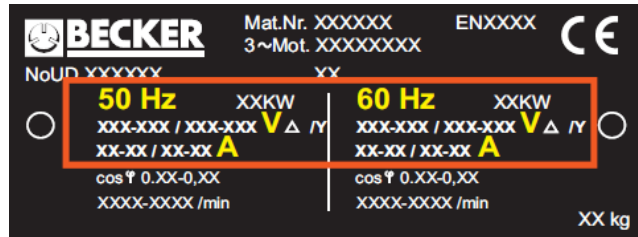

On every motor there will be the **motor nameplate**. It will state the motor electrical information with kW, Hz, voltage, amps, speed, with the wiring diagram on the motor nameplate or inside the motor box, IP rating, UL/CSA recognition, and operating mode (S1).

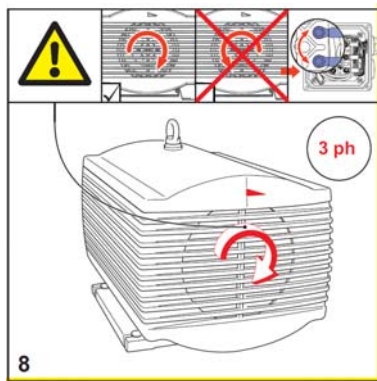

Locate the arrows that indicate correct rotation of motor/fan after electrical hook-up. Do **not reverse rotation** of the pump, this will spin the vanes backwards incorrectly and possibly break or chip vanes. **Bump** the drive motor and watch the fan wheel to determine the direction.

The pump should **not** be switched on/off more frequently than 3 times/hour or 6 times/hour if using a soft start or frequency drive.. This may lead to excess temperature limit of the motor winding and the bearings.

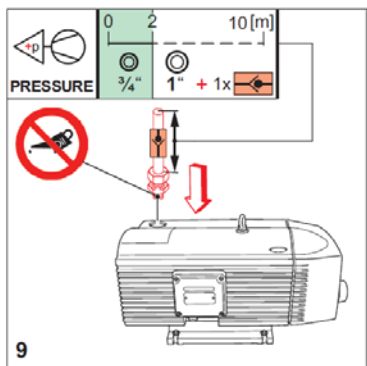

Flexible pipe should be used for pipe connections at an angle. This will prevent pipe line cracks/breakage/damage.

Proper sizing of pipe diameter should not restrict port connection. Piping diameter should be at least the same size as the port size for up to 30 meters (98 ft of equivalent length). Larger pipe diameters should be used for longer equivalent lengths (pictured here is the piping for the DT 4.40 standard).

An external check valve 1x should be used to prevent reverse operation when there is pressure in the line, due to when the machine has stopped and also when two or more pumps are paralleled/in line.

Do **not** use oil on threads of the piping.



Caution: rotating unit. Do not work on the pump/motor until it is idle with no rotation. This may take up to 3 minutes. Follow proper lockout/tag-out procedures.

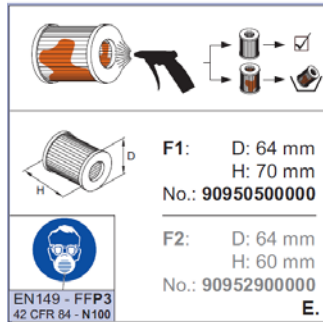
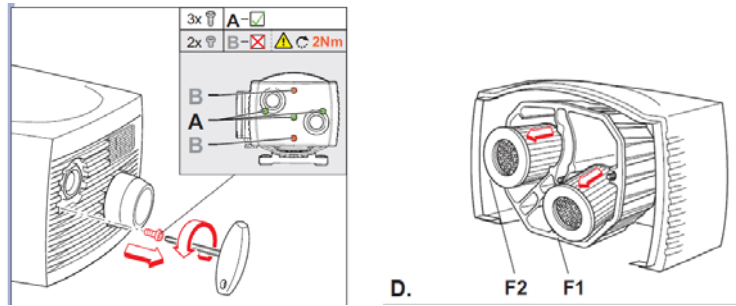

There are internal filter/elements. Every model has a filter behind the front face plastic shroud or an external filter on the inlet side of the pump (F1). In some pump types, there will also be an internal exhaust filter. (F2)

Be mindful of torque specs on bolts.

Wear dust mask and eye protection that protect against dust, debris, powders and airborne particles.

The filter elements for each model DT pump are:  
 DT 4.4 – 909580 or external filter  
 DT 4.8 – 909581 or external filter  
 DT 4.10 - 909518  
 DT 4.16 - 909519  
 DT 4.25 and DT 4.40 – 909505 (pictured here)



Filter/elements should be checked between 40-200 hours. The elements should be blown with compressed air from the inside out. Blast air should be felt coming through the filter/element. The element needs to be replaced if dirty or clogged. **Use only Becker Genuine filters to maintain warranty protection.**

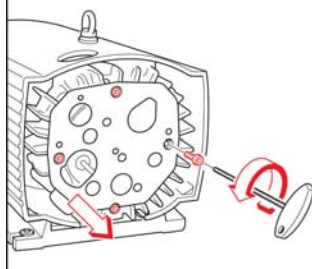

After 3000 hours of run time on the pump, the vanes will need to be checked for wear. To open vane location area, remove metal end cover, unscrew bolts.

Depending on pump type, the A max/A min = (Vane Height Max) / (Vane Height Min) is:

- 16/11 mm = DT 4.4;
- 18.5/12.5 mm = DT 4.8;
- 27/18 mm = DT 4.10;
- 35/21mm = DT 4.16;
- 43/28 mm = DT 4.25 and DT 4.40 standard models.

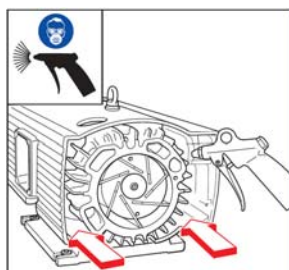

The vanes will need to be replaced when the A min (Vane Height Minimum) is reached.

Before replacement blow out the housing and the rotor slot.

When changing vanes, the sloping side (beveled) of the vane is away from the direction of rotation. Before startup, check that the vanes run freely by moving the rotor around.

**Caution:** If vanes are allowed to wear past the minimum height, the vanes may break. **Replace** vanes before reaching minimum height.

**Use only Becker Genuine vanes to maintain warranty protection.**

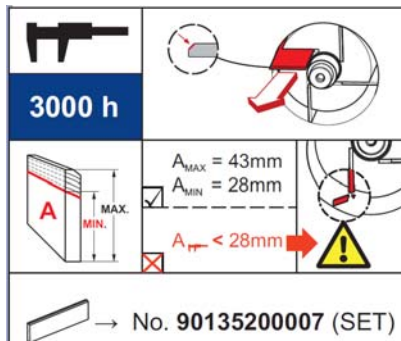

## ASK ABOUT OUR MOBILE SERVICE



**Use Only Becker Genuine Replacement Parts To Maintain  
Warranty Protection!**

### Available Spare Parts/Accessories



#### Maintenance Kit— Visit Our Store for Part #'s

Use the Becker Genuine Maintenance Kit to maintain your warranty and to increase the longevity and performance of your Becker Rotary Vane Pumps. Each of these components is engineered specifically for this pump. The kit includes Becker Genuine replacement vanes, filter, and grease gun. Keep an extra kit on the shelf to ensure you have all of the components on hand for regularly scheduled maintenance.



#### BPC Inlet Filters for Compressors

Use an inlet external canister filter with paper filter element that removes 99% of particles down to 2 micron and connects easily on to the inlet side of the Becker compressor. The air inlet filter protects the compressor from outside dust and dirt. Eliminates the need for removing covers on the pump and greatly reduces internal filter change time.



#### Check Valve Kit/Gauge

The Check Valve Kit comes complete with all parts necessary to connect to the pump. Liquid filled 0-30 psig pressure gauge with 2-1/2" face, 1/4" center back mount easily fits onto the Check Valve Kit piping.

**Visit Our Store To See All Available Parts & Accessories!**

[www.beckerpumps.com/shop](http://www.beckerpumps.com/shop)